

THE M.G. 1/4 litre Saloon, Series "Y", was the first of this *marque*, and for that matter the first Nuffield passenger car to be introduced incorporating in its design independent front wheel suspension using wishbones and coil springs. To the exceptional riding comfort and stability achieved by allowing each front road wheel to follow surface undulations without influencing the other, is added the remarkable accuracy of directional control achieved with direct-acting rack and pinion steering gear.

In this design the inner mountings of the lower wishbones are fitted with rubber bushings, which require no lubrication and form a silent and resilient pivot on the robust box-section chassis frame front cross-member. The steering swivels, or king-pins, are of a special design, the top and bottom bearings being threaded, thus providing generous bearing surfaces for both thrust and journal loads. The "track" connection from wheel to wheel is made by the steering rack as the centre section, and by two short track-rods, these having ball joints at each end. The outer ball joints are fitted with grease-gun nipples, but the inner ball sockets, enclosed in the telescopic rubber dust excluders, are oiled automatically by the rack housing lubricant,

Releasing the Springs

In ordinary maintenance it is unlikely that it will be necessary to do more than check the front wheel alignment. This is the only setting that may be affected by striking minor road obstructions or high kerbs. The correct setting is for the front road wheels to be parallel with each other. For further investigation or overhaul the procedure is to jack up the front of the car until the front tyres are just clear of the ground, using the hydraulic jacking system fitted to the car, or by placing a single jack centrally under the front chassis cross-member. The front road wheels are then removed and two additional jacks are placed under the spring pans at the outer edge. These jacks should then be operated to compress the coil spring until the hydraulic damper arms are clear of the rebound rubbers. The hydraulic brake hoses should next be disconnected, remembering that the metal pipe union nut must first be released and the frame bracket nut then removed, without allowing the hose to become twisted. Slacken the steering tie-rod locknuts and, using a spanner on the flats on the tie-rod, unscrew this from the ball joint assembly. Remove the split pins and nuts from the outer upper and lower fulcrum bolts and then draw out the bolts, noting the order of assembly of the thrust washers, rubber seals and retainers. The

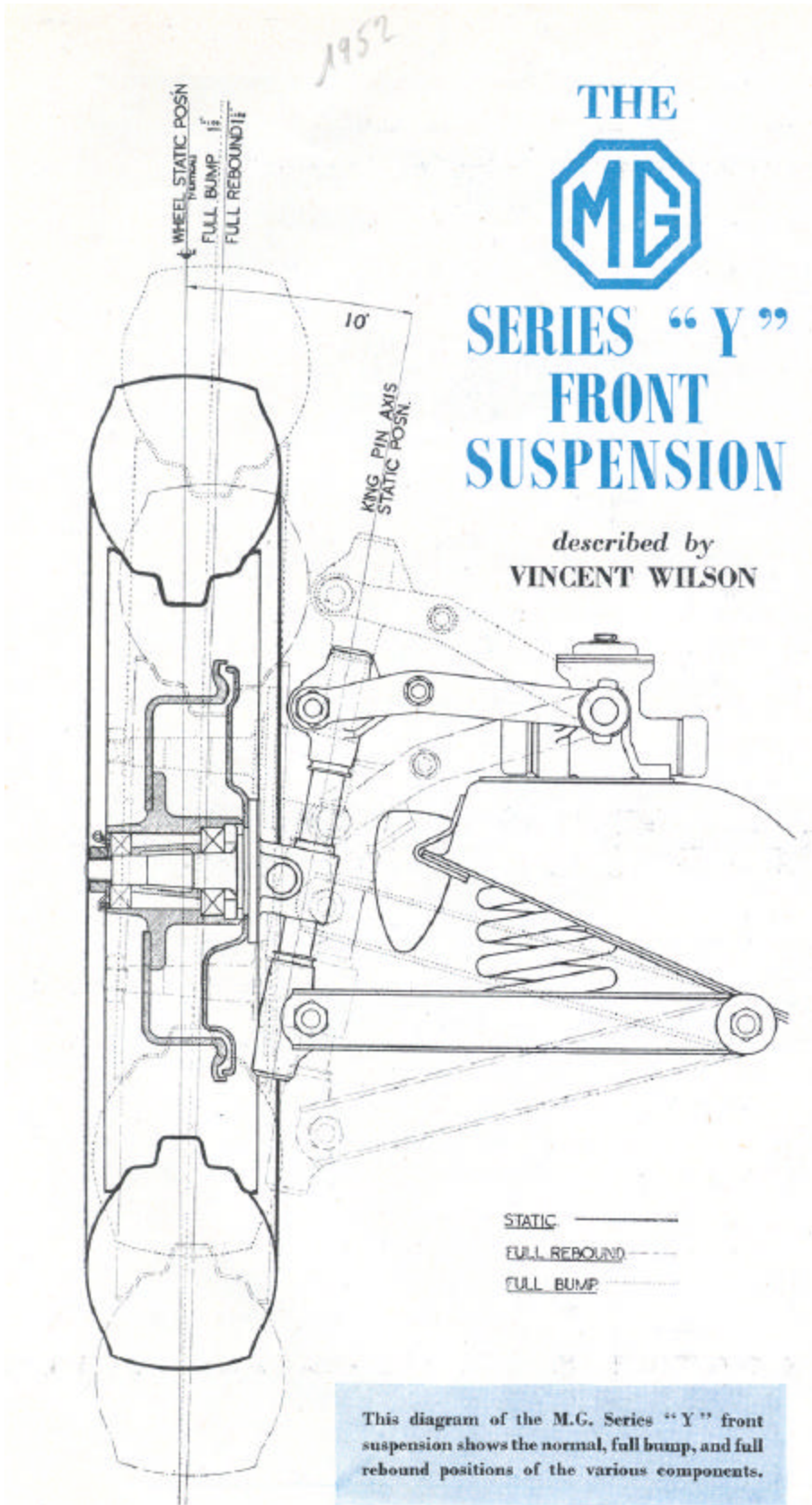

front hub and swivel pin can then be removed as a complete unit. Releasing the jacks under the spring pans will enable the latter to be pressed down sufficiently for the coil spring to be removed. The spring pan itself can then be released from the two halves of the wishbone by extracting the four nuts and bolts locating it. Next remove the split pins, nuts and washers from the inner lower fulcrum pins; the two halves of the wishbone, together with the rubber bushes, can then be extracted. Removal of the bolts securing the fulcrum pins to the chassis frame follows, with the fulcrum pins themselves.

Examination

The hydraulic dampers may now be released from the top of the chassis cross-member for cleaning, topping up, or recuperation. Each is secured by four bolts, the inner pair being screwed into the cross-member, and the outer pair having their heads on the inside of the cross-member. Inside the outer ends of the chassis front cross-member will be found the coil spring locating plates. These are each attached by one small bolt in addition to the outer damper bolts.

Examination of the front suspension parts may now be made, commencing with the rubber bushes for the inner end of the lower wishbone. If these are split, perished, eccentric or oil-soaked they should be renewed. Check the end holes in the bottom wishbones, and also the bolt holes in these parts and the corresponding ones in the spring pans for elongation. The correct bolt hole diameter is $\frac{21}{64}$ in. The coil springs should next be examined for cracks and checked for free length, which should be 9.82 in. plus or minus $\frac{1}{16}$ in. Check the swivel pin links the dimension across the thrust faces should be 2.327 in. plus or minus .0015 in. If these are appreciably worn the assembly of link and bush should be renewed. If the bush only is worn a new one should be pressed in and reamed and burnished to a finished internal diameter of .750 in. plus or minus .0005 in. It is vitally important when pressing in a new bush to ensure that the hole in it faces the threaded bore of the swivel pin link.

Hydraulic Dampers

Check the threaded bores by screwing the link on to the swivel pin. When new these are a free turning fit without any slackness. However, an appreciable amount of play is permissible in these threaded bearings. Examine the fulcrum pin distance tubes for scoring or wear. These should be 2.337 in. plus or minus .0015 in. in length and .7485 in/.7480 in. in diameter. The faces of the case-

hardened thrust washers must be free from ridges, and flat and parallel within .0005 in. When the swivel pin links, distance tubes and thrust washers are assembled the total end float should be between .007 in. and .013 in. Ensure that all grease nipples are unobstructed and the actual suspension parts are then ready for reassembly.

To check the hydraulic dampers, mount the unit on a suitable plate held in a vice and move the arm up and down through a complete stroke. If the resistance is erratic or free movement is detected this may indicate lack of fluid. While adding fluid the arm should be operated to its full stroke to expel air. If no improvement is obtained or if it is impossible to move the arm at all by hand the damper unit should be replaced. The damper arm must be able to travel a minimum of 35° each side of centre.

No adjustment is provided in the steering arm ball joints. If excessive play is present the assembly should be renewed. At this stage the brake-drums may be removed and checked for concentricity, and the braking surface examined for grooving. The brake back plate assemblies can be examined in detail, check being made on the linings, shoe pivots, and the hydraulic mechanism.

Rebuilding

The front hub bearings are Ransome & Marles notchless type-inner (large) MJ25X, and outer (small) MJ20X. As far as possible bearings which come under review during an overhaul should be cleaned and inspected without being withdrawn from the housings in which they are fitted. Unnecessary withdrawal causes deterioration of the fitting surfaces, whereas if bearings are examined in position and found serviceable, they can be left undisturbed.

To rebuild the front suspension, bolt up the coil spring locating plates inside the front cross-member and then secure the hydraulic dampers, which are inter-

changeable from side to side. The two long outer bolts have a tong flat on one side of the head which locates on the flange of the spring locating plate to prevent the bolt from turning. Bolt up the lower fulcrum pins. The two rear inner bolts have their nuts uppermost, and the six other bolts have their nuts below. Fit the rubber bushes into the lower wishbones, and to ensure central location check the outer flanges of the bushes, which should be all of equal proportions. Finally tighten the rubber bushes when the lower wishbone is parallel with the ground. Fit the spring pans to the lower wishbones, with the bob heads inside, and leave the nuts half a turn slack. Smear each end of the coil springs with grease, then press down the lower wishbone assemblies, push the coil spring up into the cross-member over the locating plates and jack up the lower wishbones until they are approximately level with the ground.

The swivel pin bearing threads are right-handed for the right of the car and left-handed for left. First lubricate and then fit the swivel pin and front hub assemblies, ensuring that the thrust washers, rubber seals and retainers are fitted in the correct order. Do not tighten fully the fulcrum bolt nuts, but leave them half a turn slack. Connect the hydraulic brake hoses, and bleed and adjust the brakes. Screw the steering tie-rods into the outer ball joints. Screwing in solid and then backing off five complete turns will give an approximate front wheel alignment setting, making the final track adjustment easier. Fit the front road wheels and lower the car to the ground. Bounce the front of the car up and down a few times to allow the fulcrums to assume the most free position, and then tighten the spring pan bolts and fulcrum bolt nuts, not forgetting to split-pin the latter. Finally adjust the front wheel alignment, again apply the grease gun to the suspension greasers, and the car is once again ready for the road.

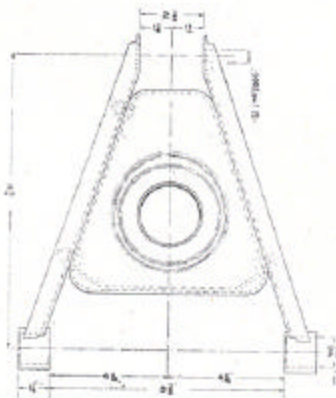

The spring pan and lower wishbone assembly, showing the main dimensions.

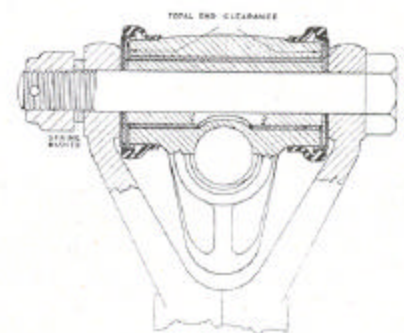

Assembly of the swivel pin and swivel link, showing thrust washers, dust excluders, etc.