

SECTION C-2
ISSUE 1, AUGUST 1950

LUCAS

Quality

EQUIPMENT

VOLUME 2

WORKSHOP INSTRUCTIONS

DISTRIBUTORS

MODELS

DKY and DKYH



JOSEPH LUCAS LTD • BIRMINGHAM 19 • ENGLAND

LUCAS WORKSHOP INSTRUCTIONS

DISTRIBUTORS

MODELS DKY and DKYH

1. GENERAL

The coil ignition equipment comprises a high tension induction coil and a combined distributor, contact breaker and automatic timing control assembly driven at half engine speed via the camshaft. Current flowing through the primary or low tension winding of the coil sets up a strong magnetic field about it. This current is periodically interrupted by a cam-operated contact breaker, driven from the engine, and the subsequent collapse of the magnetic field across the secondary winding of the coil induces a high voltage in it. At the same time, a rotor arm in the distributor connects the secondary winding of the coil with one of a number of metal electrodes, from which cables lead to the sparking plugs in the engine cylinders. Thus, a spark is arranged to occur in the cylinder under compression at the exact moment required to produce combustion of the mixture.

DKY and DKYH distributors differ only in the high tension cable attachments, Model DKY having vertical outlets and Model DKYH horizontal outlets.

Mounted on the distributor driving shaft, immediately beneath the contact breaker, is an automatic timing control mechanism. It consists of a pair of spring-loaded governor weights, linked by lever action to the contact breaker cam. At low engine speeds, the spring force maintains the cam in a position in which the spark is slightly retarded. Under the centrifugal force imparted by high engine speeds, the governor weights swing out, against the spring pressure, to advance the contact breaker cam and thereby the spark, to suit engine conditions at the greater speed.

A vacuum-operated timing control may sometimes be fitted and is designed to give additional advance under part throttle conditions by rotating the distributor body. The inlet manifold of the engine is in direct

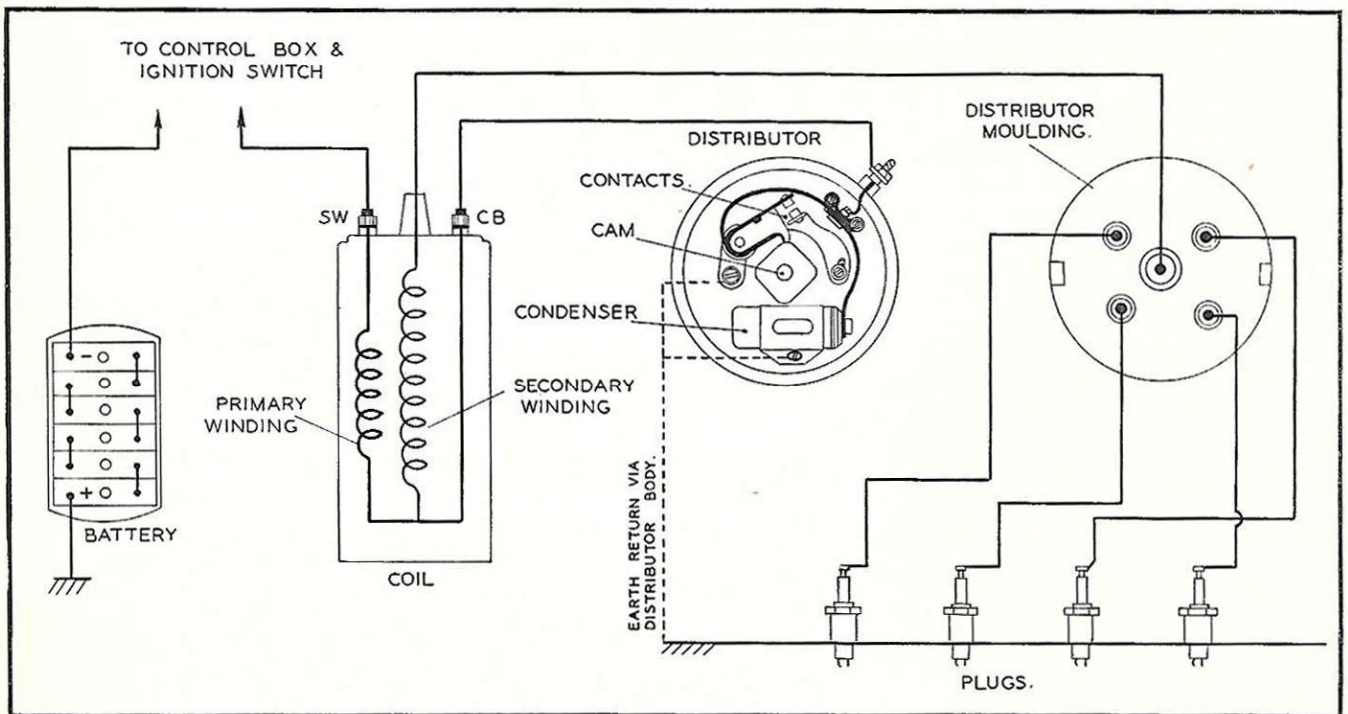

Fig. 1.
A typical coil ignition circuit



LUCAS WORKSHOP INSTRUCTIONS

communication with one side of a spring-loaded diaphragm. This diaphragm acts, through a lever mechanism, to rotate the distributor, so advancing the spark for part-throttle operating conditions. There is usually also a micrometer fine adjustment to allow for altered engine conditions, e.g., state of carbonisation, change of fuel, etc. In certain distributors, the micrometer adjustment is fitted without the vacuum operated timing control. In either case, the assembly is attached by means of a pair of clamping brackets forming the lever mechanism, one bracket being secured to the distributor body and the other fitting loosely over the distributor shank and secured to the engine block.

The combined effects of the centrifugal and vacuum operated timing controls give added efficiency over the full operating range of the engine, with a corresponding economy in fuel consumption.

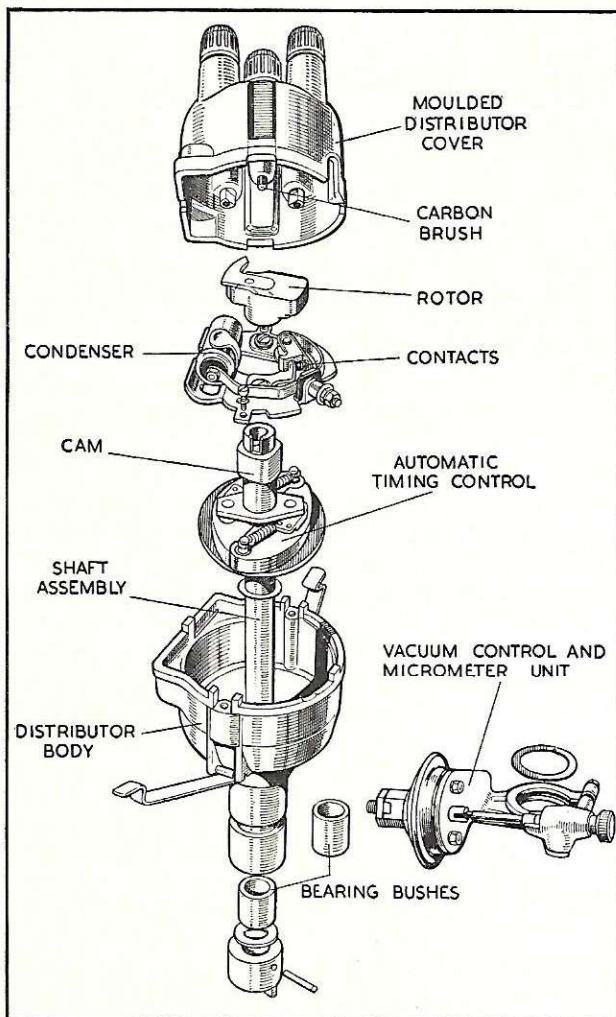

Fig. 2.
Distributor, dismantled

2. ROUTINE MAINTENANCE

In general, lubrication and cleaning constitute normal maintenance procedure.

(a) LUBRICATION — EVERY 3,000 MILES

Take great care to prevent oil or grease from getting on or near the contacts.

Lightly smear the cam with a small quantity of Mobil-grease No. 2, or, if this is not available, clean engine oil.

Apply a spot of clean engine oil to the top of the pivot on which the contact breaker works.

Lift off the rotor arm by pulling vertically and apply to the spindle a few drops of thin machine oil to lubricate the cam bearing. It is not necessary to remove the exposed screw, since it is either drilled or affords a clearance to permit passage of oil.

Replace the rotor arm carefully, locating the moulded projection in the keyway in the spindle, and pushing it on as far as it will go, in order to avoid the risk of the moulded cap being burned or tracked.

A few drops of thin machine oil should be applied, through the hole in the contact breaker base through which the cam passes, to lubricate the automatic timing control mechanism.

(b) CLEANING — EVERY 6,000 MILES

Thoroughly clean the moulded distributor cap, inside and out, with a soft dry cloth, paying particular attention to the spaces between the metal electrodes. Ensure that the small carbon brush moves freely in its holder.

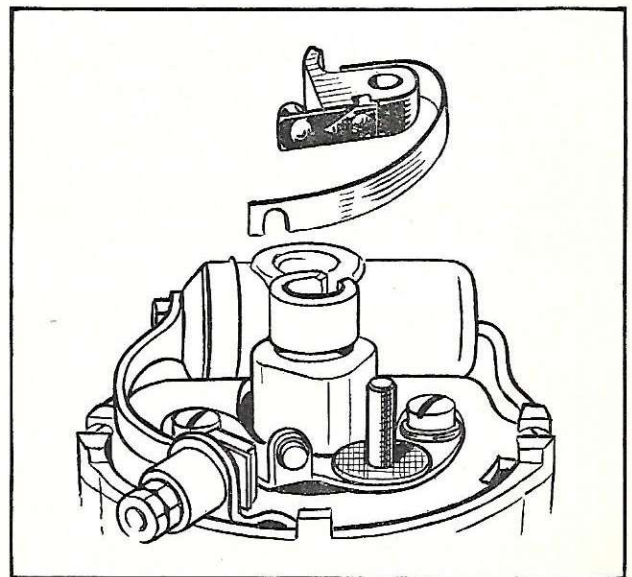

Fig. 3.
Removal of moving contact



LUCAS WORKSHOP INSTRUCTIONS

Examine the contact breaker. The contacts must be quite free from grease or oil. If they are burned or blackened, clean them with very fine carborundum stone or emery cloth, then wipe with a petrol-moistened cloth. Cleaning is facilitated by removing the contact breaker lever. This can be done by slackening the nuts on the terminal post and lifting off the spring, which is slotted for this purpose.

After cleaning, check the contact breaker setting. Turn the engine by hand until the contacts show the maximum opening. This should measure 0.010" to 0.012". If the measurement is incorrect, keep the engine in the position giving maximum opening, slacken the two screws securing the fixed contact plate and adjust its position to give the required gap. Tighten the screws. Recheck the setting for other positions of the engine giving maximum opening.

On the latest four cylinder models a new type asymmetrical cam is fitted, the purpose of which is to minimise "clicking" when the contacts close. As the number of degrees for which the contacts are fully open is smaller with this type of cam, it is important when checking the gap on these distributors to ensure

that the rocker heel of the contact breaker is actually at the highest point of the lobe on the cam.

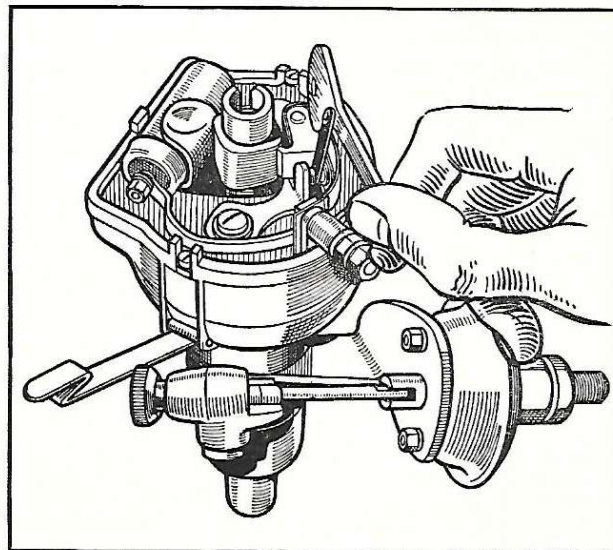

Fig. 4.
Checking the contacts

3. (a)

DESIGN DATA

	Open Period	Closed Period	Firing Angles
2 cylinder models	$90^{\circ} \pm 4^{\circ}$	$90^{\circ} \pm 4^{\circ}$	$0^{\circ}, 180^{\circ}, \pm 1^{\circ}$
4 cyl. models (symmetrical cam) ...	$45^{\circ} \pm 4^{\circ}$	$45^{\circ} \pm 4^{\circ}$	$0^{\circ}, 90^{\circ}, 180^{\circ}, 270^{\circ} \pm 1^{\circ}$
4 cyl. models (asymmetrical cam) ...	$41^{\circ} \pm 4^{\circ}$	$49^{\circ} \pm 4^{\circ}$	$0^{\circ}, 90^{\circ}, 180^{\circ}, 270^{\circ} \pm 1^{\circ}$

- (b) Contact breaker gap : 0.010" to 0.012".
 (c) Contact breaker spring tension, measured at contacts : 20 — 24 oz.
 (d) Condenser capacity : 0.2 microfarad.
 (e) Automatic timing control : the operating range of the mechanism varies with each car model, and is

given in the Test Data section of the appropriate C.E. list. The performance of the control may be checked against these figures if the requisite equipment is available.

- (f) For current consumption figures, etc., of ignition coils, see SECTION C-8.

4. SERVICING

Before starting to test, make sure that the battery is not fully discharged, as this will often produce the same symptoms as a fault in the ignition circuit.

(a) TESTING IN POSITION TO LOCATE CAUSE OF UNEVEN FIRING

Run the engine at a fairly fast idling speed.
 Short circuit each plug in turn with, say, the blade of

an insulated handled screwdriver or a hammer head placed across the terminal to contact the cylinder head. Short circuiting the defective plug will cause no noticeable change in the running note. On the others, however, there will be a pronounced increase in roughness.

Having thus located the defective cylinder, stop the engine and remove the cable from the sparking plug terminal.



LUCAS WORKSHOP INSTRUCTIONS

Restart the engine and hold the cable end about $\frac{3}{16}$ " from the cylinder head. If sparking is strong and regular, the fault lies with the sparking plug, and it should be removed, cleaned and adjusted, or a replacement fitted.

If, however, there is no spark, or only weak irregular sparking, examine the cable from the plug to the distributor for deterioration of the insulation, renewing the cable if the rubber is cracked or perished.

Clean and examine the distributor moulded cap for free movement of the carbon brush. If tracking has occurred, indicated by a thin black line, usually between two or more electrodes, a replacement distributor cap must be fitted.

(b) TESTING IN POSITION TO LOCATE CAUSE OF IGNITION FAILURE

Spring back the clips on the distributor head and remove the moulded cap. Lift off the rotor, carefully levering with a screwdriver if necessary.

Check the contacts for cleanliness and correct gap setting as described in Para. 2(b).

If an ammeter is fitted, switch on the ignition and turn the engine. Observe the reading, which should rise and fall with the closing and opening of the contacts if the low tension wiring is in order. When the reading does not fluctuate, a short circuit, or contacts remaining closed, is indicated. No reading indicates a broken or loose connection in the low tension wiring, or badly adjusted or dirty contacts.

(c) LOW TENSION CIRCUIT — FAULT LOCATION

If it is suspected that the fault lies in the low tension circuit, switch on the ignition and turn the engine until the contact breaker points are fully opened.

Refer to the wiring diagram (published in the appropriate C.E. list) and check the circuit with a voltmeter (0—20 volts) between the following points (which refer to a normal ignition layout) AND A GOOD EARTH.

If the circuit is in order, the voltage reading should be approximately 6 or 12 volts, according to the system. No reading indicates a damaged cable or loose connections, or a breakdown in the section under test.

(i) BATTERY TO AMMETER

Connect the voltmeter between the ammeter terminal "B" and a good earth on the chassis. In some systems this section of the circuit is made by way of the starter switch, in which case a voltage check should also be made at the battery connection to the switch. No reading indicates a faulty lead or loose connection.

(ii) AMMETER

Check the voltage to earth at the other ammeter terminal "A". No reading indicates a faulty ammeter.

(iii) AMMETER TO CONTROL BOX

Connect the voltmeter between the control box terminal "A" and earth. No reading indicates a faulty lead or loose connection.

(iv) CONTROL BOX

Check the voltage to earth at the control box terminal "A1." No reading indicates a broken connection in the series winding.

(v) CONTROL BOX TO IGNITION SWITCH

Connect the voltmeter between the ignition switch terminal, to which the lead from the control box is connected, and a good earth. No reading indicates a faulty lead or loose connection.

(vi) IGNITION SWITCH

Check the voltage between the other terminal of the ignition switch and earth. No reading indicates a fault in the switch.

(vii) IGNITION SWITCH TO IGNITION COIL

Remove the lead from the ignition coil "SW" terminal, and connect the voltmeter between the free end of the cable and earth.

On systems incorporating control boxes models RF91 and RF95, this portion of the circuit is made by way of the control box "A3" terminal, and a voltage check should be made at this point also. Remake the connection to the coil.

(viii) IGNITION COIL

Disconnect the lead from the "CB" terminal of the coil and connect the voltmeter between the "CB" terminal and a good earth. No reading indicates a fault in the primary winding of the coil, necessitating coil replacement. If, however, the correct reading is obtained, remake the cable connection to the coil terminal.

(ix) IGNITION COIL TO DISTRIBUTOR

Disconnect the low tension cable to the distributor and connect the voltmeter between the end of the cable removed and earth. No reading indicates a faulty lead or loose connection. Reconnect the cable to the distributor.

(x) CONTACT BREAKER AND CONDENSER

Connect the voltmeter across the contact points. If no reading is obtained, re-check with the condenser removed. If a reading is now given, the condenser is faulty and must be replaced.

(xi) Measure the contact breaker spring tension. This should be 20—24 oz., measured at the contacts.



LUCAS WORKSHOP INSTRUCTIONS

(d) HIGH TENSION CIRCUIT

If, after carrying out these tests, the fault has not been located, remove the high tension lead from the centre terminal of the distributor. Switch on the ignition and turn the engine until the contacts close.

Flick open the contact breaker lever while the high tension lead from the coil is held about $\frac{3}{16}$ " from the cylinder block. If the ignition equipment is in good order, a strong spark will be obtained. If no spark occurs, a fault in the circuit of the secondary winding of the coil is indicated and the coil must be replaced.

The high tension cables must be carefully examined, and replaced if the rubber insulation is cracked or perished, using 7 mm. rubber covered ignition cable.

To fit cables to ignition coils and distributors with vertical outlets, pass the cable through the knurled, moulded nut, bare about $\frac{1}{4}$ " of the end of the cable, thread the wire through the brass washer (removed from the original cable) and bend back the strands. Finally screw the nut into its terminal.

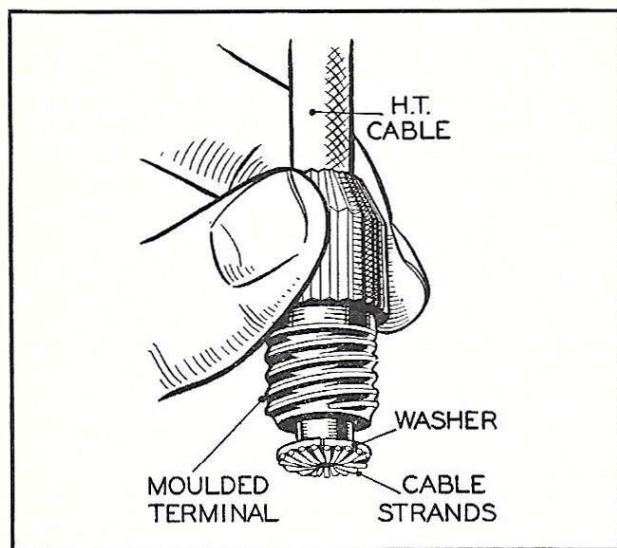

Fig. 5.

Fitting terminal nut to high tension cable (ignition coil, and distributor with vertical outlets)

To make connections to the terminals in distributor caps having horizontal outlets, remove the cap and slacken the screws on the inside of the moulding. Cut the cables to the length required and push firmly home in the holes in the moulding. Tighten the

screws, which will pierce the rubber insulation to make good contact with the cable core.

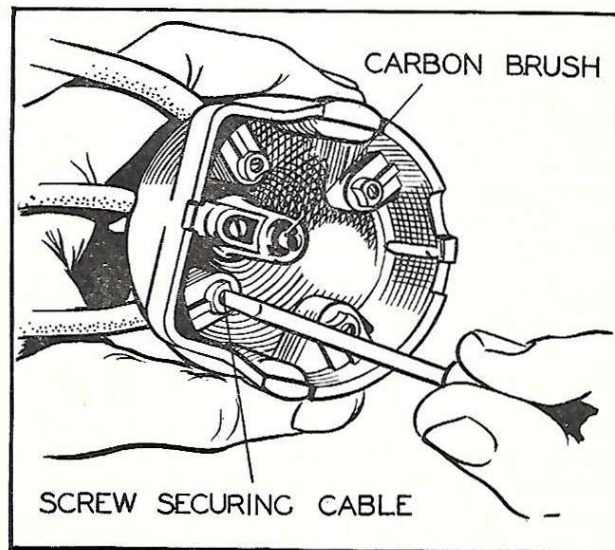

Fig. 6.

Making connections to distributors with horizontal high tension cable outlets

The cables from the distributor to the sparking plugs must, of course, be connected in the correct firing order.

(e) CONTACT BREAKER MECHANISM

Check and adjust as described in Para. 2 on page 3. Ensure that the moving arm moves freely on its pivot. If sluggish, remove the arm and polish the pivot pin with a strip of fine emery cloth. Replace the arm and lubricate with a spot of clean engine oil.

(f) DISMANTLING

Before dismantling, carefully note the positions in which the various components are fitted, in order to ensure their correct replacement on subsequent reassembly. If the driving member is offset, or marked in any way for convenience in timing, note the relation between it and the rotor electrode, and maintain this relation when reassembling the distributor.

(i) Spring back the securing clips and remove the moulded cap.

(ii) Lift the rotor arm off the top of the spindle. If tight, carefully lever off with a screwdriver.



LUCAS WORKSHOP INSTRUCTIONS

(iii) Slacken the nut on the terminal post and lift off the contact breaker spring. The contact breaker lever can now be lifted from its pivot. Lift the fibre washer from the pivot. Remove the two screws, together with the spring and plain steel washers, securing the fixed contact plate, and remove the plate.

(iv) Undo the two screws with spring washers from the edge of the contact breaker base, which can now be removed from the distributor body.

(v) To remove a faulty condenser, unscrew the condenser terminal nut, lift off the spring washer and remove the connector strip. Soften the solder securing the condenser in its clip by use of a hot iron and remove the condenser by applying pressure at one end. A special tool (Part No. GHS/R. 1164) is effective for this purpose. See Para. (g).

(vi) Remove the dog or driving gear from the shaft.

(vii) Remove the cam, automatic timing control and shaft assembly from the distributor. Take out the screw from inside the top of the cam spindle. Lift off the cam and cam-foot.

(g) CONDENSER — REPLACEMENT

Should the condenser have been found to be faulty when testing, see Para. (c), page 4, it is advisable to fit a complete new condenser and contact breaker base. If, however, only a condenser is available, great care must be taken not to overheat it, when soldering it in position.

(h) BEARING BUSHES — REPLACEMENT

Bushes are removed and fitted using a vertical drilling machine or hand press in which is fitted a highly polished mandrel of the same size as the distributor shaft.

To remove the bushes, locate the distributor body (inverted) beneath the press. A sleeve must be fitted over the mandrel, to enlarge it to the size of the bushes. Apply a steady pressure, to force the bushes from their seats. Remove the sleeve.

New bushes must be completely immersed in thin engine oil for 24 hours before fitting. In cases of emergency, this process may be shortened by heating the oil to 100°C., when the period of immersion may be reduced to 2 hours.

Place a long bush on the mandrel, then the distributor body (inverted) and finally one of the smaller bushes. Locate the lower end of the mandrel in a suitable packing block (see Fig. 8) and apply a steady downward pressure. Ensure that both bushes enter the distributor squarely. When they have been fully inserted, carefully withdraw the mandrel.

Under no circumstances should the bushes be overbored by reamering or any other means, since this will impair the porosity and thereby the effective lubricating quality of the bushes.

(j) REASSEMBLY

(i) Before assembly, the automatic advance mechanism, distributor shaft and the portion of the shaft on which the cam fits, must be lubricated with thin engine oil.

(ii) Assemble the automatic timing control, taking care that the parts are fitted in their original positions

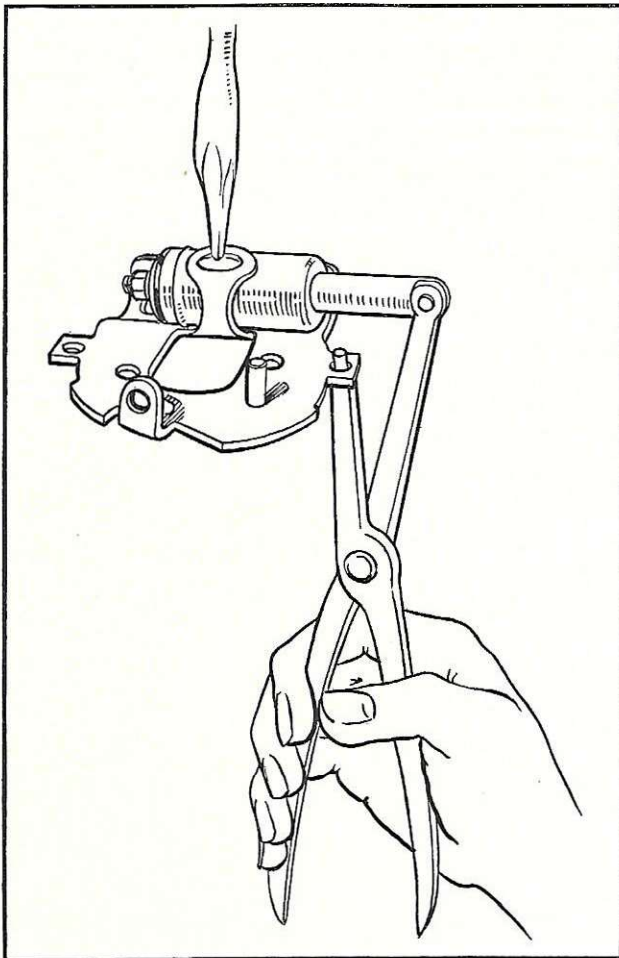

Fig. 7.
Tool for condenser removal



LUCAS WORKSHOP INSTRUCTIONS

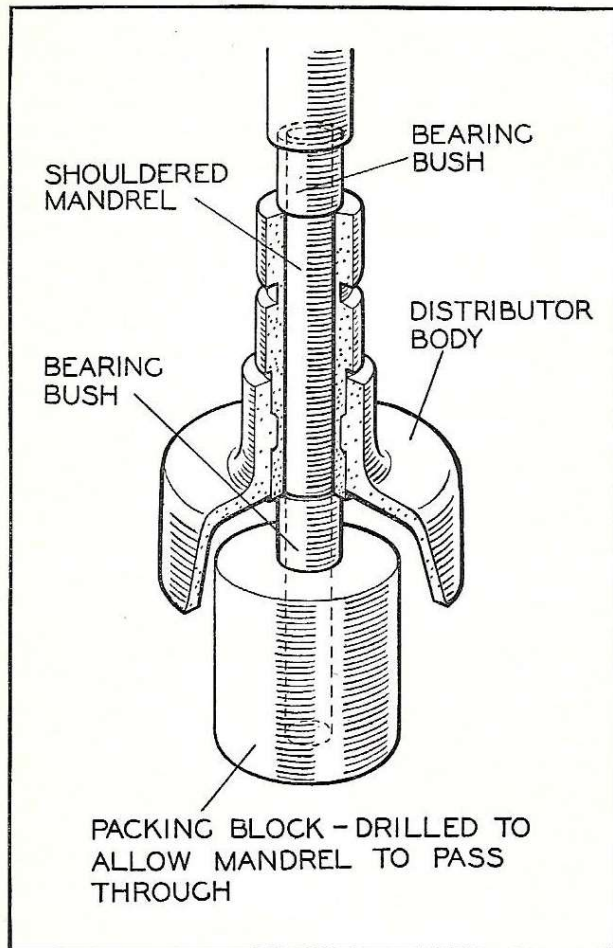

Fig. 8
Replacement of bearing bushes

and the control springs not stretched. Two holes are provided in each toggle for the control springs, which must in each case be fitted to the inner hole. Place the cam on the spindle and secure with the locking screw.

(iii) Fit the shaft in its bearings and replace the driving member.

(iv) Place the contact-breaker base in position on the distributor body, securing by replacing the two side screws. Spring washers must be fitted under each screw head and the screws firmly tightened.

(v) Place the end of the connector strip over the condenser terminal post, refit the spring washer and secure by tightening the terminal nut.

(vi) Replace the fixed contact plate on the contact-breaker base, fit the two screws, together with their plain and spring washers, and lightly tighten. Place the insulating washer over the contact-breaker pivot pin and fit the contact-breaker lever on the pin. Locate the slotted end of the contact-breaker spring under the head of the terminal screw and tighten the nut to lock the spring in position. Adjust the contact-breaker setting to give a gap of 0.010" to 0.012" when the contacts are fully opened.

N.B.—If it is necessary to renew the contacts, a replacement set comprising fixed and moving contacts must be fitted.

(vii) Place the rotor on the spindle, locating the register correctly and pushing the rotor fully home.

(viii) Fit the distributor cover moulding and secure by means of the spring clips.

